

MX-X Technical Data  
Very Narrow Aisle Truck (man-up)  
with Turret Head or Telescopic Fork

---

MX-X/Li-Ion

---



MX-X Very Narrow Aisle Truck (man-up) with Turret Head or Telescopic Fork  
Perfection in Performance and Comfort



				STILL	STILL	STILL	STILL
Features	1.1	Manufacturer					
	1.2	Manufacturer's type designation		<b>MX-X/Li-Ion with turret head</b>	<b>MX-X/Li-Ion with turret head</b>	<b>MX-X/Li-Ion with telescopic fork</b>	<b>MX-X/Li-Ion with telescopic fork</b>
	1.3	Drive		Electric	Electric	Electric	Electric
	1.4	Operation		Stand-on/rider seated	Stand-on/rider seated	Stand-on/rider seated	Stand-on/rider seated
	1.5	Rated capacity/load		Q kg	1500	1250	1250
	1.6	Load centre		c mm	600	600	600
Weights	1.9	Wheel base		y mm	1992	2212	1992
	2.1	Service weight (incl. battery)		kg	8410	11150	8088
	2.2	Axle load with load		drive end/load end kg	2573/7337	3698/8702	2384/6954
Tyres/chassis	2.3	Axle load without load		drive end/load end kg	3362/4972	4349/6801	3173/4915
	3.1	Tyres			Vulkollan	Vulkollan	Vulkollan
	3.2	Tyre diameter/width		drive end mm	406/170	406/170	406/170
	3.3	Tyre diameter/width		load end mm	370/160	370/160	370/160
	3.5	Number of wheels (x = driven)		drive end/load end	1x/2	1x/2	1x/2
	3.6	Track width		drive end/load end b <sub>10</sub> /b <sub>11</sub> mm	1245/0	1595/0	1145/0
Basic dimensions	4.2	Height		mast lowered h <sub>1</sub> mm	3900	5400	3400
	4.3	Free lift		h <sub>2</sub> mm	-	4150	-
	4.4	Lift		h <sub>3</sub> mm	5200	11550	4200
	4.5	Height		mast extended h <sub>4</sub> mm	7785	14135	6785
	4.7	Height of overhead guard (cabin)		h <sub>6</sub> mm	2555	2555	2555
	4.8	Stand height, lowered		h <sub>7</sub> mm	460	460	460
	4.11	Auxiliary fork lift		h <sub>9</sub> mm	1800	1800	800
	4.14	Stand height, raised		h <sub>12</sub> mm	5660	12010	4660
	4.14.1	Reach height (h <sub>12</sub> + 1600)		h <sub>28</sub> mm	7260	13610	6260
	4.15	Height lowered		h <sub>13</sub> mm	60	60	380
	4.19	Overall length (incl. fork)		l <sub>1</sub> mm	3622	3937	3847
	4.21	Overall width, load wheel axle		b <sub>1</sub> /b <sub>2</sub> mm	1160/1450	1160/1800	1160/1350
	4.22	Fork dimensions		s/e/l mm	50/120/1190	50/120/1205	65/174/1200
	4.24	Width of fork carriage		b <sub>3</sub> mm	710	710	830
	4.25	Outer fork width		min./max. b <sub>5</sub> mm	470/640	470/640	545/545
	4.27	Width over guide rollers		b <sub>6</sub> mm	1640	1870	1475
	4.29	Shift, sideways		b <sub>7</sub> mm	1305	1398	1340
	4.31	Floor clearance with load, beneath mast		m <sub>1</sub> mm	40	40	40
	4.32	Floor clearance centre wheel base		m <sub>2</sub> mm	87	87	87
	4.34	Working aisle width		A <sub>st</sub> mm	1645	1875	1480
	4.35	Turning radius		W <sub>a</sub> mm	2248	2468	2248
	4.38	Distance fork pivot point		l <sub>8</sub> mm	1019	1114	1269
	4.39	Length of shift carriage		A mm	480	575	-
4.40	Width of shift frame		B mm	1465	1540	-	
4.41	Width of shift carriage		F mm	250	310	-	
4.42	Width of transition aisle, min.		A <sub>u</sub> mm	4041	4466	4222	
4.44	Clear width cabin access		mm	412	412	412	
4.45	Headroom clearance cabin		mm	2000	2000	2000	
Performance data	5.1	Driving speed		laden/unladen km/h	14.0/14.0 <sup>1</sup>	12.0/12.0	14.0/14.0 <sup>1</sup>
	5.2	Lift speed		laden/unladen m/s	0.6/0.6	0.48/0.53	0.6/0.6
	5.3	Lowering speed		laden/unladen m/s	0.45/0.45	0.45/0.45	0.45/0.45
	5.4	Shift speed		laden/unladen m/s	0.29/0.29	0.30/0.30	0.25/0.25
	5.9	Acceleration time (10 m)		laden/unladen s	6/6	7/7	6/6
	5.10	Service brake			Regenerative	Regenerative	Regenerative
Electric engine	6.1	Drive motor, capacity S2 = 60 min		kW	7.0	7.0	7.0
	6.2	Lift motor, capacity S3 = 15%		kW	24.0	24.0	24.0
	6.3	Battery according to IEC 254-2; A, B, C, no			IEC 254-2; A	IEC 254-2; A	IEC 254-2; A
	6.4	Battery type, voltage, rated capacity K <sub>s</sub>		V/Ah	PzS, 80 V, 700 Ah	PzS, 80 V, 930 Ah	PzS, 80 V, 700 Ah
	6.5	Battery weight ±5% (depends on manufacturer)		kg	1863	2178	1863
Misc.	8.1	Type of truck control microprocessor			Microprocessor	Microprocessor	Microprocessor
	8.4	Sound level, driver's ear		dB(A)	68	68	68

<sup>1</sup> Depends on configuration

MX-X Very Narrow Aisle Truck (man-up) with Turret Head or Telescopic Fork  
 Technical Drawings

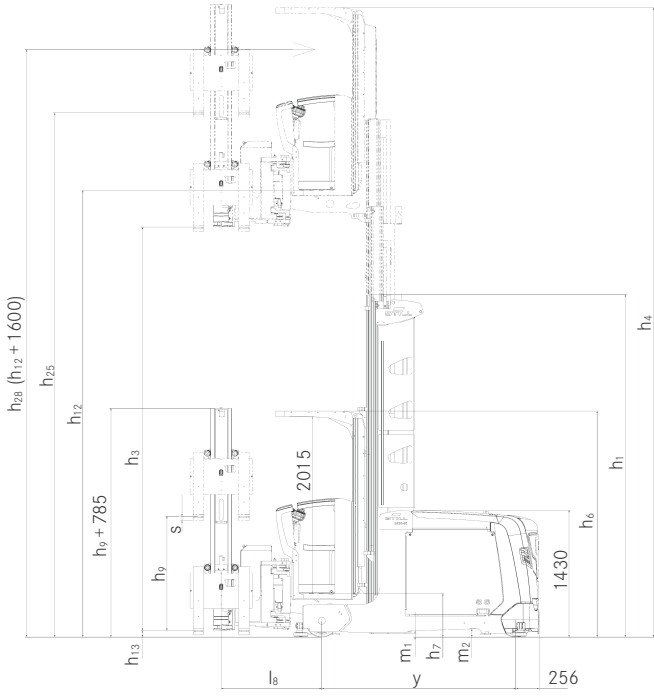

MX-X with turret head - side view

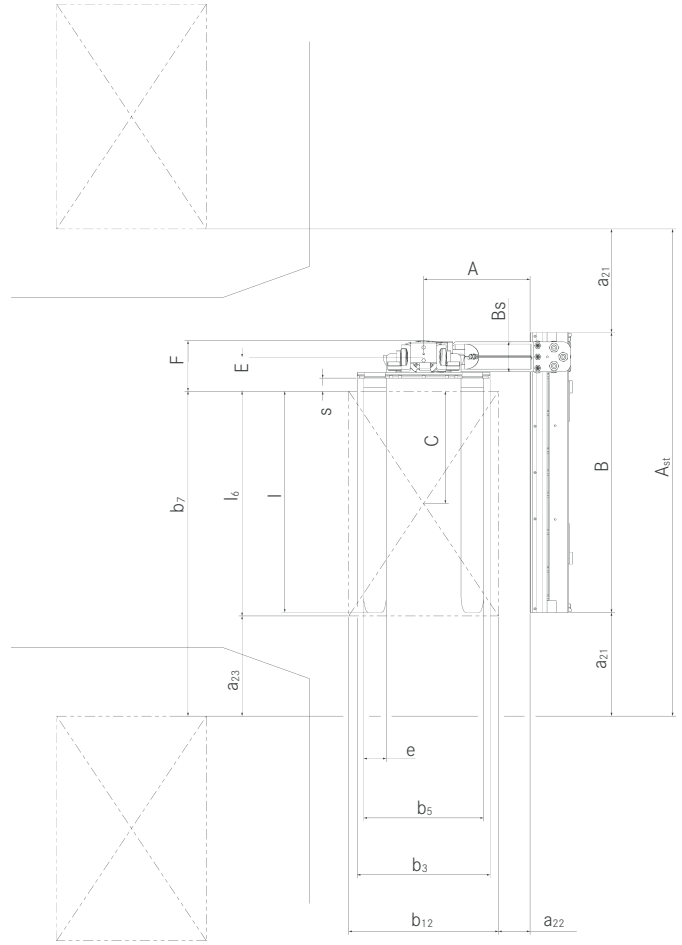

Turret head - top view

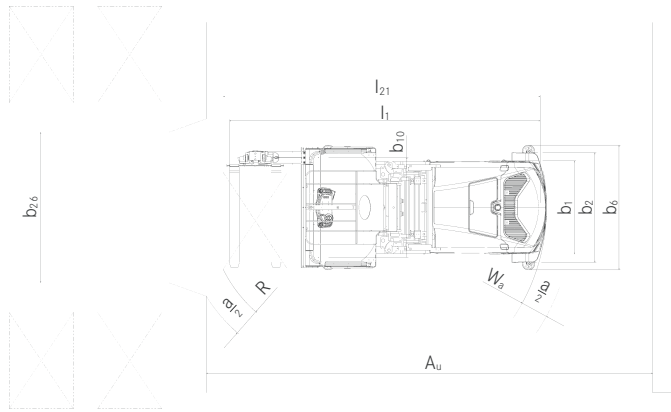

MX-X with turret head and mechanical guidance - top view

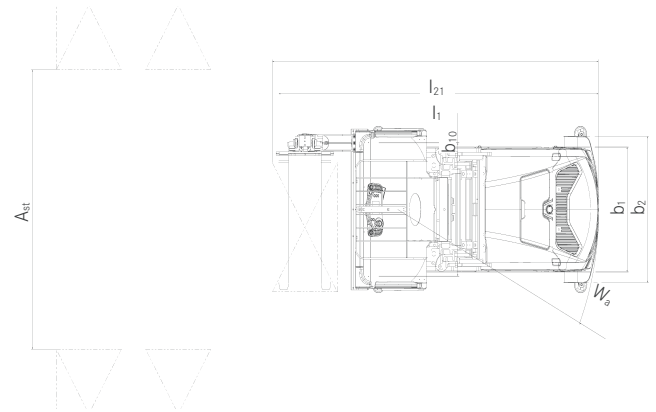

MX-X with turret head and inductive guidance - top view

MX-X Very Narrow Aisle Truck (man-up) with Turret Head or Telescopic Fork  
 Technical Drawings

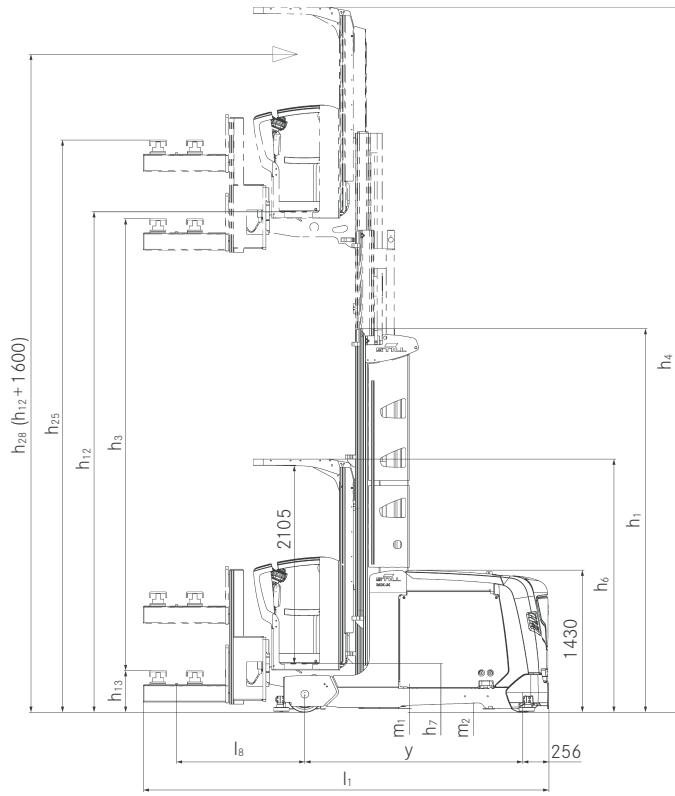

MX-X with telescopic fork - side view

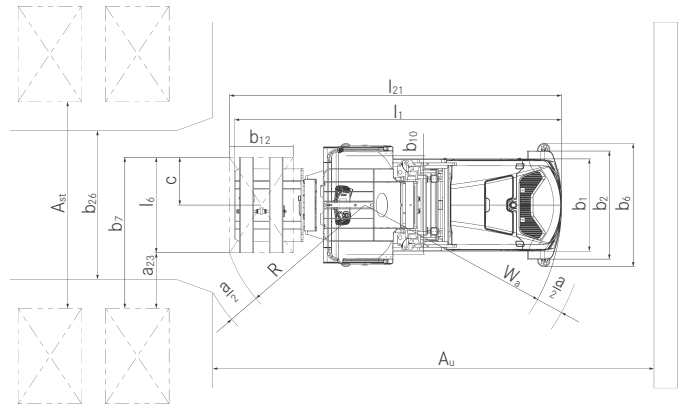

MX-X with telescopic fork and rail guidance - top view

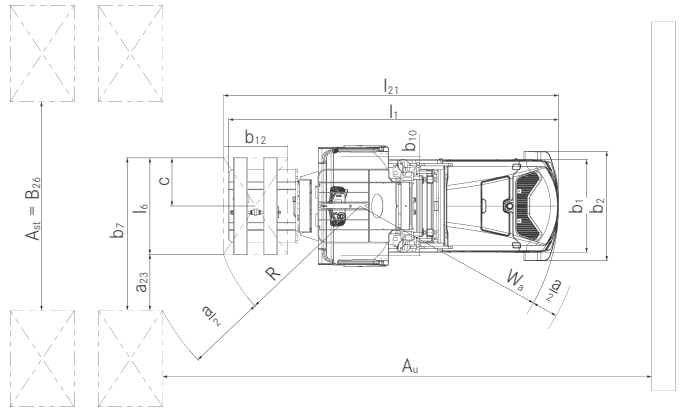

MX-X with telescopic fork and inductive guidance - top view

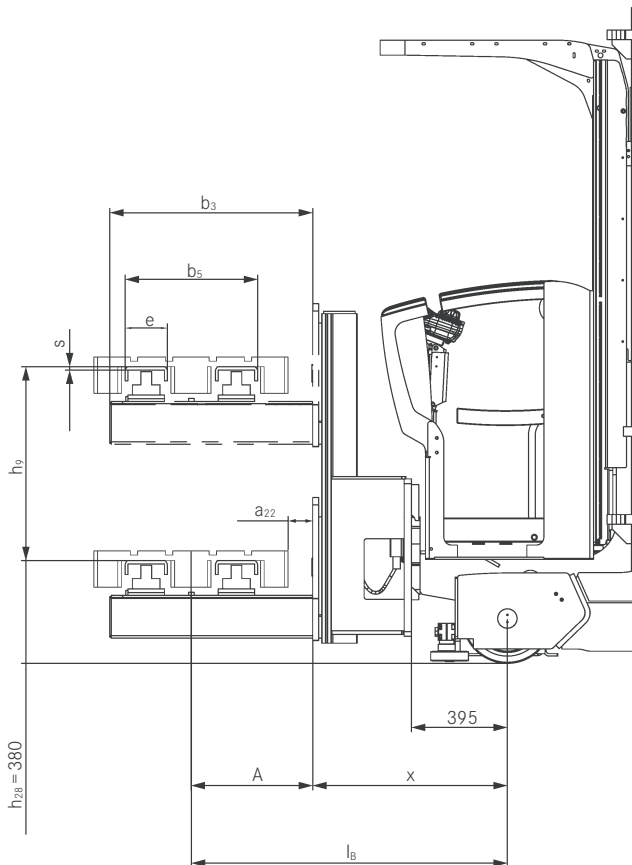

MX-X with high telescopic fork - side view

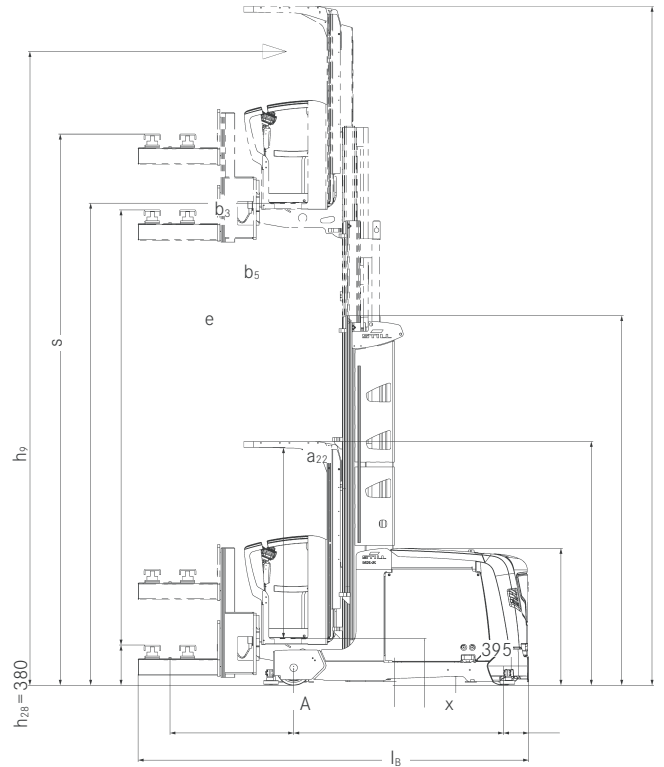

MX-X with low telescopic fork - side view

## MX-X Very Narrow Aisle Truck (man-up) with Turret Head or Telescopic Fork Mast Tables

### MX-X with turret head

Telescopic mast (all heights indicated in mm)

Overall height $h_1$	Overall lift above floor $h_{25} (h_3 + h_9 + h_{13})$	Overall lift $h_{24} (h_3 + h_9)$	Lift $h_3$	Height lowered $h_{13}$	Auxiliary lift $h_9$	Stand height $h_{12} (h_3 + h_7)$	Reach height $h_{28} (h_{12} + 1600)$	Maximum height $h_4$
2400	4060	4000	2200	60	1800	2660	4260	4785
2900	5060	5000	3200	60	1800	3660	5260	5785
3400	6060	6000	4200	60	1800	4660	6260	6785
3900	7060	7000	5200	60	1800	5660	7260	7785
4400	8060	8000	6200	60	1800	6660	8260	8785
4900	9060	9000	7200	60	1800	7660	9260	9785
5400	10060	10000	8200	60	1800	8660	10260	10785
5900	10860	10800	9000	60	1800	9460	11060	11585
6400	11860	11800	10000	60	1800	10460	12060	12585
6900	12660	12600	10800	60	1800	11260	12860	13385
7400	13660	13600	11800	60	1800	12260	13860	14385

Triplex mast with free lift (all heights indicated in mm)

Overall height $h_1$	Overall lift above floor $h_{25} (h_3 + h_9 + h_{13})$	Overall lift $h_{24} (h_3 + h_9)$	Lift $h_3$	Height lowered $h_{13}$	Auxiliary lift $h_9$	Stand height $h_{12} (h_3 + h_7)$	Reach height $h_{28} (h_{12} + 1600)$	Maximum height $h_4$
2900	6910	6850	5050	60	1800	5510	7110	7635
3400	8210	8150	6350	60	1800	6810	8410	8935
3900	9310	9250	7450	60	1800	7910	9510	10035
4400	10610	10550	8750	60	1800	9210	10810	11335
4900	11910	11850	10050	60	1800	10510	12110	12635
5400	13410	13350	11550	60	1800	12010	13610	14135
5900	14710	14650	12850	60	1800	13310	14910	15435
6400	16210	16150	14350	60	1800	14810	16410	16935
6900	17510	17450	15650	60	1800	16110	17710	18235

### MX-X with telescopic fork

Telescopic mast (all heights indicated in mm)

Overall height $h_1$	Overall lift above floor $h_{25} (h_3 + h_9 + h_{13})$	Overall lift $h_{24} (h_3 + h_9)$	Lift $h_3$	Height lowered $h_{13}$	Auxiliary lift $h_9$	Stand height $h_{12} (h_3 + h_7)$	Reach height $h_{28} (h_{12} + 1600)$	Maximum height $h_4$
2400	3380	3000	2200	380	800	2660	3860	4755
2900	4380	4000	3200	380	800	3660	4860	5755
3400	5380	5000	4200	380	800	4660	5860	6755
3900	6380	6000	5200	380	800	5660	6860	7755
4400	7380	7000	6200	380	800	6660	7860	8755
4900	8380	8000	7200	380	800	7660	8860	9755
5400	9380	9000	8200	380	800	8660	9860	10755
5900	10180	9800	9000	380	800	9460	10660	11555
6400	11180	10800	10000	380	800	10460	11660	12555
6900	11980	11600	10800	380	800	11260	12460	13355
7400	12980	12600	11800	380	800	12260	13460	14355

Triplex mast with free lift (all heights indicated in mm)

Overall height $h_1$	Overall lift above floor $h_{25} (h_3 + h_9 + h_{13})$	Overall lift $h_{24} (h_3 + h_9)$	Lift $h_3$	Height lowered $h_{13}$	Auxiliary lift $h_9$	Stand height $h_{12} (h_3 + h_7)$	Reach height $h_{28} (h_{12} + 1600)$	Maximum height $h_4$
2900	6230	5850	5050	380	800	5510	7110	7605
3400	7530	7150	6350	380	800	6810	8410	8905
3900	8630	8250	7450	380	800	7910	9510	10005
4400	9930	9550	8750	380	800	9210	10810	11305
4900	11230	10850	10050	380	800	10510	12110	12605
5400	12730	12350	11550	380	800	12010	13610	14105
5900	14030	13650	12850	380	800	13310	14910	15405
6400	15530	15150	14350	380	800	14810	16410	16905
6900	16830	16450	15650	380	800	16110	17710	18205

MX-X Very Narrow Aisle Truck (man-up) with Turret Head or Telescopic Fork  
Detailed Photos



Individually adjustable rear view mirrors for easy access into the aisles



Comfortable work standing and seated



Compact and ergonomic control panel with colour display and driver information



Three-dimensional positioning of the control panel



Tilting bar for ergonomic order picking to the last article on the pallet



Upholstered knee protector and cup holder for comfortable work



Versatile support system for individual work spaces



Spacious work space with multiple supports for accessories



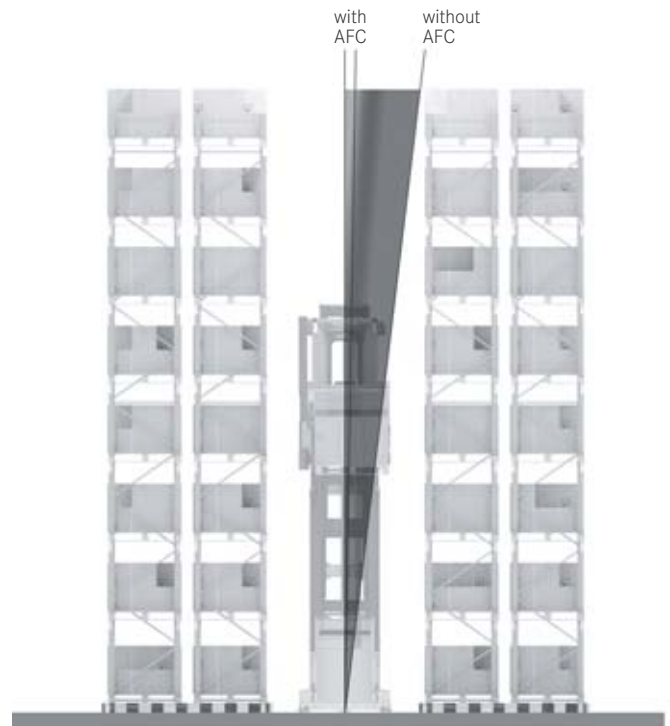

---

## Active Floor Compensation (AFC)

### **Active Floor Compensation (AFC) – Maximum performance also with uneven floors.**

The floors in VNA warehouses need to be of a high quality. Should they be uneven or have any traces of wear, these will be transferred directly to the forklift truck in the form of vibrations. For maximum speeds and efficiency to be achieved, the floor needs to be absolutely level. Reconditioning the floor is not only costly, it also prevents the warehouse from being fully utilised while the work is being carried out.

### **Active assistance system: AFC**

With the assistance system for the MX-X Very Narrow Aisle Truck, STILL offers a genuine alternative to reconditioning the warehouse floor. The

system identifies any uneven surfaces in the load wheels' path and compensates for them in real time. This ensures that the truck frame always remains horizontal and the mast vertical. The AFC system – the only one of its kind on the market – has ultra-fast processors which allow it to react instantaneously, even when travelling at top speeds. In contrast to passive systems that only have a dampening effect, this system actively prevents vibrations before they occur.

**Reduced vibrations – higher handling performance.** Preventing mast vibrations protects the load, the warehouse and the driver and, last but not least, facilitates a significant increase in handling capacity with the help of AFC.

---

## Active Load Stabilisation (ALS)

### **Unique around the world: STILL Active Load Stabilisation (ALS):**

Active load stabilisation is unique in narrow aisle operations. It not only increases comfort, but also optimises the pushing movement when loading and picking. The hydraulic control inhibits mast vibrations and increases handling capacity by up to 5 percent.

## STILL OptiSpeed 4.0

**OptiSpeed 4.0 – Navigation aid for the driver.** This system optimises the approach to the destination by stopping forks automatically at the horizontal and vertical target position. The positioning is determined by means of distance measuring and comparison with the current position (via RFID transponders or barcodes). OptiSpeed 4.0 differentiates between loading, unloading and order picking at the target position, and adjusts the lifting height of the fork automatically.



## STILL OptiSafe

This system supports you with configurable speed and function adjustments in storage areas which call for special safety regulations,

e.g. in the event of obstacles, height restrictions or the ends of aisles.

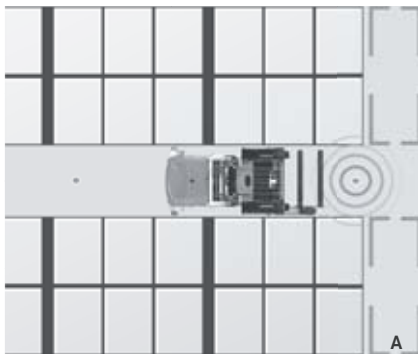

**Optimised braking distances (A):** At the end of the aisle, the forklift truck decelerates gently in relation to the speed and lifting height, which increases handling capacity.

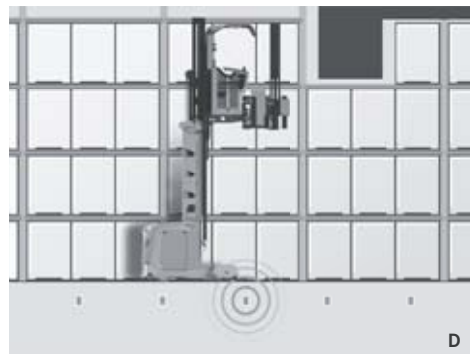

**Collision avoidance (D):** Known obstacles can be defined. The driver does not have to memorise all the features of the warehouse and can concentrate on his or her work.

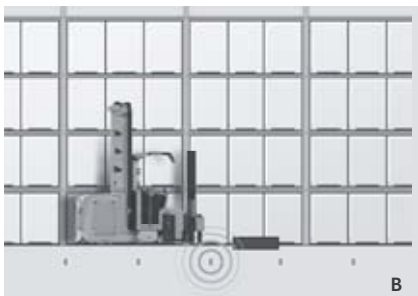

**Automatic speed adjustment (B):** In defined zones, speed adjustments can be set automatically based on the ground conditions.

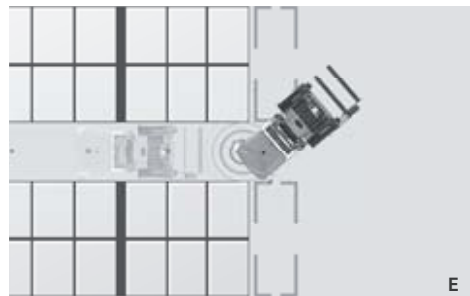

**Aisle exit assistant (E):** The steering can be locked for a defined stretch, e.g. when exiting an aisle to avoid collisions.

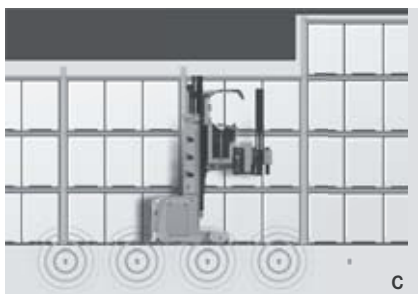

**Height limitation (C):** The adjustable height limitation enables optimum use of space right up to the ceiling in halls of different heights.

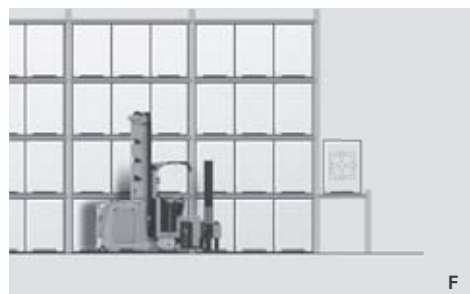

**Position selection (F):** The position selection enables a targeted approach to defined, frequently used positions, such as transfer points.



## MX-X Very Narrow Aisle Truck (man-up) with Turret Head or Telescopic Fork Perfection in Performance and Comfort

---

**Optimum use of storage space: 18-metres lift height and highest residual load capacity**

**Fast storage and retrieval: Active load stabilisation (ALS) to reduce mast oscillations**

**Maximum possible working comfort: Spacious and flexibly adjustable driver's cabin**

**Maximum travel speeds: Active Floor Compensation (AFC) compensates for uneven ground**



Innovative technologies and smart modularity: The STILL MX-X VNA Very Narrow Aisle Truck (man-up) sets standards in performance and user-friendliness. Developed to optimally handle any challenge, the MX-X scores with performance packages for every application profile. Thus you receive a truck precisely adapted to your individual requirements - from its dimensions to its technical features. The focus is on the operator: A spacious and flexibly adaptable driver's cabin, intuitive controls and smart assistance systems promise safe, comfortable and efficient work throughout a whole shift.

Driving speeds of up to 14 km/h, a lift height of up to 18 metres and the highest residual load capacity on the market make the MX-X a turnover champion in highly compacted warehouse worlds. Whilst the active load stabilisation (ALS) notably shortens storage and retrieval processes by up to 5%, the mechanism of the turret head promises even shorter picking distances. Thanks to the fully welded auxiliary lift, the MX-X scores with maximum stability throughout its service life. The STILL MX-X high bay order pickers can be individually configured according to your requirements and will thrill you with their excellent functionality.

## Extensive Equipment

---

### Power

---

- Effective load handling due to very high drive and lift speeds of up to 14 km/h; 0.6 m/s
- High turnover performance: Simultaneous operation of the main and auxiliary lift
- Best performance: Individual performance packages for every application profile
- Full of energy for multi-shift applications: High battery capacities and Li-Ion Ready (48 V)
- High speeds: Active Floor Compensation (AFC) compensates for uneven floors

### Precision

---

- Fast storage and retrieval: Active load stabilisation (ALS) reduces mast oscillations and increases turnover by up to 5%
- Maximum storage density: Lift height of 18 metres
- Precision on the push of a button: STILL colour display with freely programmable favourite keys, optional lift height pre-selection and driver information
- Safe and effortless work: Semi-automatic positioning with OptiSpeed 4.0

### Ergonomics

---

- Top work comfort: Height-adjustable control panel with ergonomic steering knob, intuitive controls and colour display
- Safe functionality: Optional tilting barriers for even better access to the rack

- Cabins for every type of application: From wind protection to cold store cabin
- Great freedom of movement: Cabin sizes for any requirement
- Healthy and relaxed work: Shock-absorbing cabin floor, large foot section and optimum placement of the drive switch

### Compactness

---

- Maximum storage density with customer-specific truck dimensions
- Compact turret head with short order picking distance

### Safety

---

- Safe functionality: OptiSafe assistance system for flexible adaptation of speeds and functions for defined areas in the warehouse
- Safe storage and retrieval: Standard reach control depending on lift height and load capacity
- Audible and visible safety: Rescue Alert emits acoustic and visual warnings in case of abnormal driver behaviour
- Optimum visibility: Large window to pick up load carriers from the floor

### Environment

---

- Longer service times: Energy recovery when braking and lowering
- Reduced noise emission: Optimised design of the hydraulic systems
- Reduced energy consumption on the push of a button: Blue-Q efficiency mode saves up to 12 per cent of energy without affecting the performance of the fleet

# MX-X Very Narrow Aisle Truck (man-up) with Turret Head or Telescopic Fork Equipment Variants



	MX-X With turret head	MX-X With telescopic fork	
Driver's seat	Ergonomic, shock absorbing seat with horizontal and tilt adjustment	●	●
	Seat variants with arm rests and heating or air-suspended comfort seat	○	○
	Shock-absorbing work space for optimum comfort on bumpy floors and trespases	●	●
	Combi cabin for freedom of movement when order picking or stacking	●	●
	Comfort cabin for greatest freedom of movement	○	○
	Many different cabin widths (1,070-1,970 mm)	●	●
	Cold store version for temperatures up to -30 °C	○	○
	Heights overhead guard 1,900/2,000/2,200 mm	○/●/○	○/●/○
	Single centrally placed control panel with ergonomic steering knob to control the truck	●	●
	Two-piece control panel integrated in the armrests of the seat for seated and standing driving	○	○
	Colour display to indicate operating states	●	●
	Tilting barrier for optimum reach	○	○
	Full glass swivel door for the closed cabin	○	○
	Upholstered backrest for standing truck operation	●	●
	Knee upholstery for support when order picking	○	○
	Mounting support to attach storage compartments for small utensils (load end and/or lift end)	○	○
	Flexible bar system for individual work space layout (load end and/or mast end)	○	○
	Adjustable rear view mirrors, optionally with integrated LED lighting and fans	○	○
	LED lights to light the cabin	○	○
	LED spot light for the rack	○	○
	Reversing camera system with 180° field of vision consisting of one or two cameras	○	○
	Integrated storage compartments, for example for writing pad, bottles, or USB socket	○	○
	Prepared for installation of standard car radios	○	○
Electric and mechanic preparation for data terminal	○	○	
Performance packages	OPTISPEED 3.0: Basic equipment with reach control	●	●
	OPTISPEED 3.1: Load detection for speed optimisation	○	○
	OPTISPEED 3.3: Weight and load detection for speed optimisation	○	○
	OPTISPEED 3.4: Active load stabilisation and weight and load detection for speed optimisation	○	○
	OPTISPEED 4.0: Semi-automatic specialist approach	○	○
	Active Floor Compensation (AFC): Assistance system to compensate for uneven floors for maximum driving speed	○	○
	Performance package lifting	○	○
Performance package driving	○	○	
Safety	OPTISAFE: Customised safety and flexibility in narrow aisles	○	○
	FleetManager: access authorisation, shock detection, reports	○	○
	Rescue Alarm for atypical user input to attract attention	○	○
	Reach control depending on lift height and load weight for safe storage and retrieval	●	●
	Automatic end-of-aisle stop with pedestrian protection system, RFID tags or magnetic switches	○	○
	Rail guidance with entrance rollers	●	●
	Inductive guidance with automatic loop finder	○	○
	Increased residual load capacity for heavy loads at large heights	○	○
	Automatic fork cycle for faster and safer load change, integrated in the control panel	○	○
	Lift height pre-selection for faster positioning at the storage bay and for stacking	○	○
	PIN code access, keyless with push button	○	○
	Warning light, drive end for better perception of the truck	●	●
	Warning light, load end	○	○
	STILL Safety Light	○	○
	Acoustic warning when driving in load and/or drive direction	○	○
	Adjustable lift cutoff and lowering stop	○	○
	Contactless collision guard on the OHG	○	○
Installed rope rescue system, ready for use	●	●	
Hydraulics	Over shift function for turret head	○	—
	Symmetric hydraulic fork arm adjustment	○	—
	Parallel hydraulic fork arm adjustment	○	—
	Hydraulic fork arm adjustment single fork arm	○	—
	Auxiliary functions attachment	○	—
	Mast transition damping	●	●
	Auxiliary lift h <sub>o</sub>	●	●
	Noise-optimised hydraulic pump	●	●
Energy recovery when lowering	●	●	
Drives	Jerk-free, stepless acceleration up to top speed	●	●
	Maintenance-free drives for driving, steering and lifting	●	●
	Fully encapsulated, dirt and dust resistant components	●	●
	Regenerative brake system for energy recuperation when braking	●	●
Additional hydraulic load wheel brake	○	○	
Battery	48-V battery compartment for 480 to 1240 Ah	○	○
	80-V battery compartment for 360 to 930 Ah	○	○
	Li-Ion Ready for the 48-V battery compartment	○	○
	Battery roller track for lateral battery change	○	○
Electronic battery lock monitor	●	●	

More options and modules available.

● Standard ○ Optional — Not available

# STILL



STILL Materials Handling Ltd  
Aston Way  
Leyland Preston  
PR26 7UX  
Tel.: +44 (0)845 603 6827

STILL Materials Handling Ltd  
Jacks Way  
Hill Barton  
Business Park  
Clyst St. Mary  
Exeter  
EX5 1FG  
Tel.: +44 (0)345 603 6827  
info@still.co.uk

**For further information please visit:**

**[www.still.co.uk](http://www.still.co.uk)**

STILL is certified in the following areas: Quality management, occupational safety, environmental protection and energy management.



first in intralogistics